

Aerometals



INLET BARRIER FILTERS

SINGLE ENGINE
HELICOPTERS

Designed for **Maximum Efficiency**

Utilizing the **latest generation Computational Fluid Dynamics** modeling software, Aerometals Engineers have created one of the most efficient filter designs on the market.

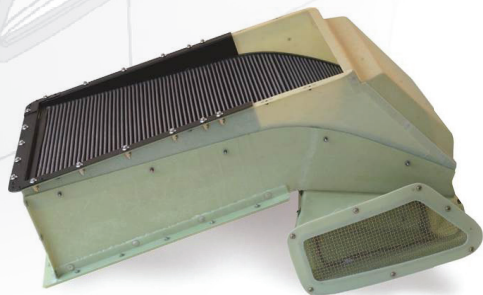

Legacy EC130 Design

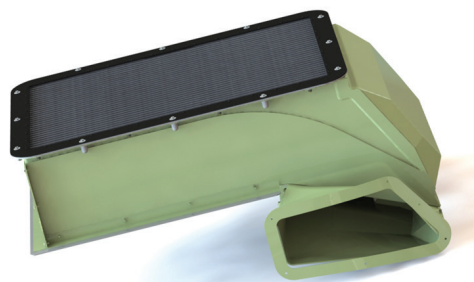
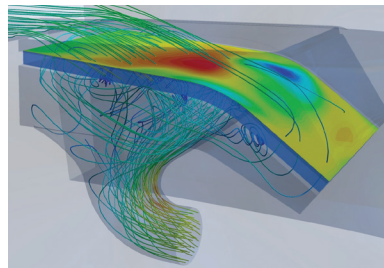

Nex-Gen H130 Design

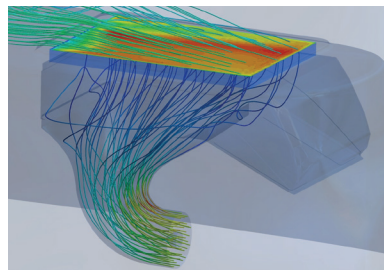

EFFICIENCY

- Results:
- Minimal Installation Losses
 - Certified for Use with Existing Performance Charts

Using **lightweight composite** materials and integrated cowling designs enables minimization of the overall system weight.

LIGHT WEIGHT

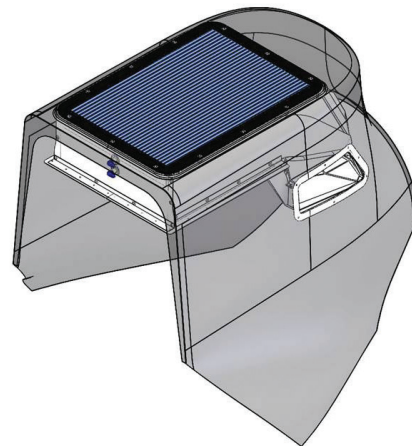
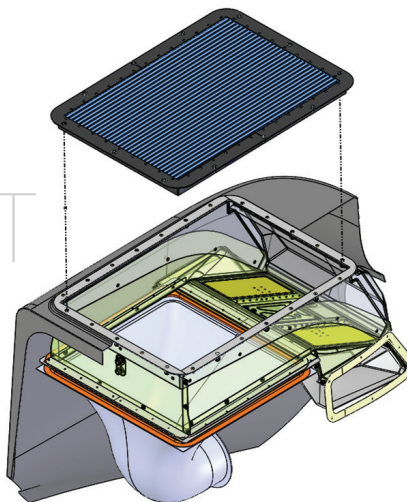

Providing Complete Engine Protection and Flight Safety

Protection that will extend your engine life and reduce your overhaul costs by minimizing Erosion, FOD Events, Fouling, and the corrosive effects of airborne salt nuclei present in coastal operations.

Erosion & FOD Damage

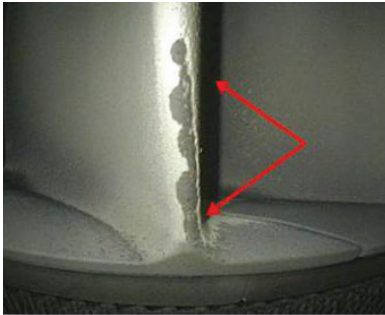

Stops 99.3% of SAE Test Dust Preventing premature erosion

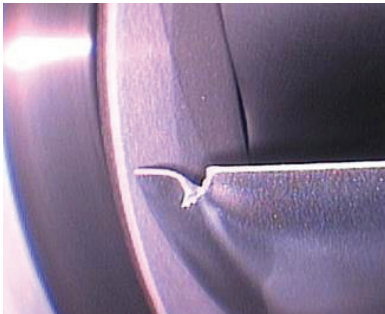

Fouling



Hollow shaft at 800 hours with no IBF



Hollow shaft at 1500 hours with IBF installed

Corrosion

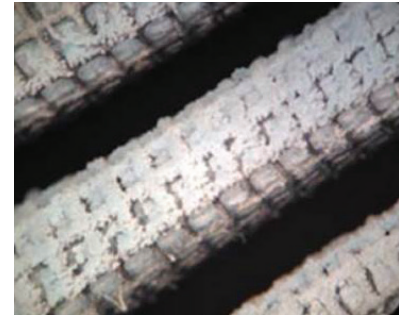

Up to 96.8% separation efficiency of airborne salt nuclei present in coastal operations







Neutralize the Environment™

Unrestricted **Revenue** Possibilities

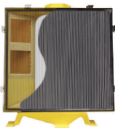
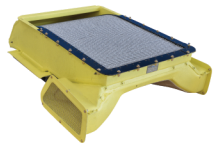
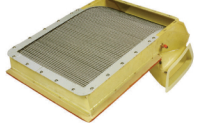
OFFSHORE
UTILITY
PARAPUBLIC
MEDEVAC

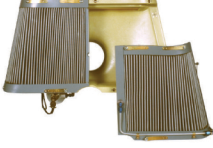
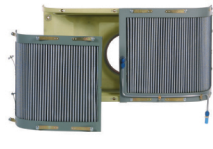
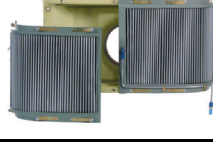

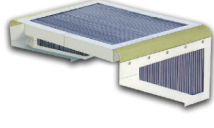
OEM	Model	Weight	Est. Install	Eligible for Installation
Airbus Helicopters	 EC120	16.4 lbs.	10-12 hrs.	EC120B
	 AS350	16.4 lbs.	40 hrs.	H125 (AS350B3e), AS350B, BA, B1, B2, B3, D, D1, SD1, SD2, FX1, FX2
	 EC130B4	16.4 lbs.	40 hrs.	EC130B4
	 H130	20.3 lbs.	40 hrs.	H130 (EC130T2)
Bell Helicopters	 Bell 206	11.6 lbs.	10-12 hrs.	206A, B, B-1, B-2, B3 OH-58A, A+, C
	 Bell 206L	18.0 lbs.	10-12 hrs.	206L1(C30P), L-1+, L-3 L-3+, L-4
	 Bell 407	18.0 lbs.	10-12 hrs.	407
MD Helicopters	 MD500	18.0 lbs.	50-70 hrs.	369C, HM, HS, HE, D, E, F, FF
	 MD600	12.2 lbs.	10-12 hrs.	600N

Aerometals

Please contact us at 916.939.6888
or visit our website at www.aerometals.aero



DESIGN
FLY
CERTIFY
MANUFACTURE

We do
it ALL.